

DBH DISC BRAKES CALIPER air applied spring released

NIIKA®

The **DBH** is an economic caliper brake, which offers a wide variety of thrusters and features.

Easy Pad Change: The pads can be changed in a couple of minutes

Asbestos Free Pads : The standard pads fitted are asbestos free.

Brake Discs: The DBH204,205 designed for disc thickness 20MM and OD over 200mm

Torque Formula : Braking Torque (kgm) =Braking Force (kg) x Effective Disc Radius (Actual)(mm)



LEFT TYPE

Size	DBH 204	DBH 205
Maximum under overload	7 kg/cm ²	7 kg/cm ²
Compression ratio	1.83	1.83
Disc thickness	20 mm	20 mm
Disc O. D. mm	200↑	200↑
Unit Weight	9 kg	9.5 kg

Every **horizontal** caliper separate into the left and right type. Please indicate left or right side type when order.

● Torque versus Pressure

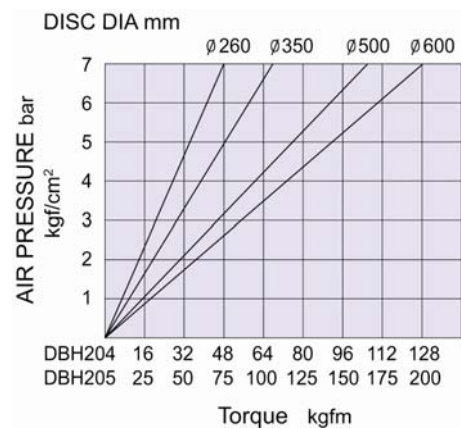

APPROXIMATE DIMENSION

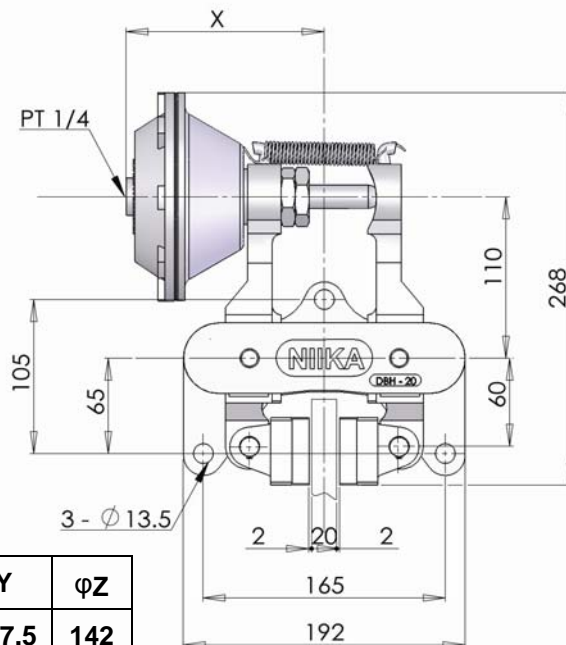

Size	X	Y	φZ
DBH 204	135	267.5	142
DBH 205	155	285	177

RIGHT TYPE

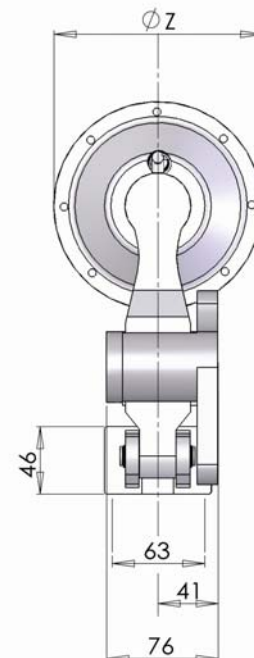

Warning : The initial torque on new units can be 30% to 50% less then the catalogue value until the friction facing and friction disc are lapped or worn in. NIIKA Limited reserves the right to modify or change the design without prior notice.