

benzlers 
with you at every turn

Series J - Shaft Mounted Gearbox
Installation & Maintenance



radicon 
with you at every turn

Installation of hollowshaft gear

The hollowshaft gear is normally mounted on a shaft with js6 tolerance. The shaft bore has H7 tolerance.

The gear unit is lifted using suitable holes for the purpose: J11-72, using torque arm hole, J100-190 using torque arm hole or lifting lug supplied.

The shaft must be lubricated with Molycote BR2 or the supplied tube with copper grease, before fitting the gear unit. The gear unit must not be driven onto the shaft by force

When fitting a pulley wheel without a compression bushing the threaded hole in the input shaft must be used. A threaded hole in the shaft is not standard on size J11-32. The pulley wheel must not be driven on the shaft with force. The pulley wheel stop screw must be countersunk in the key. The stop screw must be locked.

The torque arm must be positioned so that it is in tension. This is determined by the direction of rotation of the output shaft. If rotation is anticlockwise the torque arm must be placed on the right (see fig1.) If the direction is reversible or unit is operating under harsh conditions then two torque arms must be fitted.

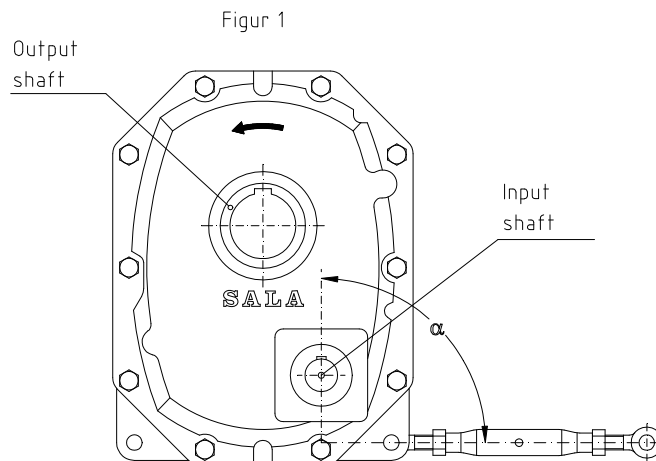

C40501

The torque arm should be located in $90^{\circ} +0^{\circ} / -45^{\circ}$.

If a backstop is fitted, the direction of rotation of the motor must be checked before fitting the pulley belts.

For applications with heavy duty and/or when speed reducer is mounted in angle of inclination from horizontal machine shaft, locking washer must be used.

Lubrication

The oil filling system of the SALA speed reducers means simplified maintenance and oil exchange. Front and back (on some sizes even sides) of reducer are equipped with oil level plugs.

The first oil change shall be made after 2500 operating hours. At operation temperatures up to 70°C we recommend oil change after 8000 operating hours or every 2 years. At operation temperatures above 70°C , oil must be changed twice a year. These recommendations apply for operations without shocks. When mounting reducer on vertical shaft or when the gearbox is working above or below recommended output speed please contact Benzlers or the local representative.

SALA speed reducers are normally delivered without oil. Different mounting positions need different oil volumes.

Recommended type of oil and grade of viscosity according ISO VG.

Ambient temperature

-20° C - +10° C

+5° C - +30° C

-15° C - +40° C

Grade of viscosity

ISO VG 68 EP

ISO VG 220 EP

ISO VG 220 Syntetic.

At other ambient temperatures please contact Benzlers or the local representative.

Oil quantities and oil level plugs.

The figures in the first column under each respective mounting position, shown in the table, refer to the approximate quantities of oil for gear units mounted according to these positions. If it is required to mount a gear unit in any other position, Benzlers or your local representative should be consulted.

Approximate quantity of oil in litres.

(Ref. Number of oil level plug.)

J	H1	H2	H3	H4	H5	H6
11A/11B	0,9(10)	0,8(10)	0,9(3)	0,4(3)	0,3*	1,5*
21A/21B	1,1(10)	1,3(10)	1,0(3)	0,3(3)	0,6*	2,3*
31A/31B	2,4(10)	2,1(10)	2,2(3)	1,1(3)	1,6*	3,9*
51A/51B	4,3(5)	3,5(9)	3,9(3)	1,9(3)	2,2*	6,3*
71A/71B	5,9(6)	5,3(5)	5,4(12)	2,5(11)	2,8*	8,6*
12A/12B	1,0(10)	0,4(10)	0,8(3)	0,4(3)	1,2*	1,3*
22A/22B	1,6(10)	0,6(10)	1,4(3)	0,6(3)	1,9*	2,1*
32A/32B	2,4(10)	1,1(10)	1,0(3)	0,9(3)	3,1*	3,4*
52A/52B	4,5(5)	1,6(9)	3,7(3)	1,9(3)	4,8*	5,6*
72A/72B	5,7(6)	2,4(5)	5,1(12)	2,4(11)	7,5*	8,3*
100 1-step	11(6)	11,5(4)	9(3)	3(10)	14(13)	16(13)
110 1-step	20(6)	15,5(4)	3,5(3)	7(10)	28(13)	28,5(13)
125 1-step	38(6)	26,5(4)	9,5(3)	4,5(10)	37(13)	38(13)
100 2-step	10(6)	>50rpm 4,5(2) <50rpm 9(4)	8(3)	3(10)	12,5(14)	14,5(13)
110 2-step	20,5(6)	8(2)	11,5(3)	7(10)	25,5(14)	25,5(13)
125 2-step	24(6)	15(2)	9(3)	4,5(10)	34(14)	35(13)
140 2-step	38(6)	13(2)	24(3)	11(10)	45(14)	45(13)
160 2-step	52(6)	21(2)	36(3)	17(10)	67(14)	64(13)
190 2-step	65(6)	23(2)	46(3)	27(5)	108(14)	112(13)

C37004-38.doc

*) Oil gauge tube.

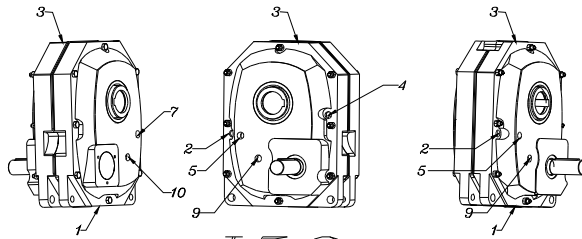

J52

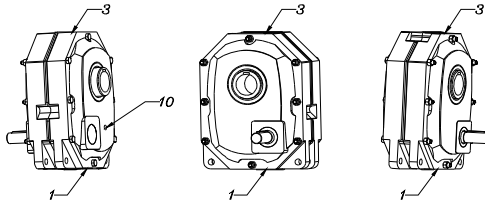

J11 - J32

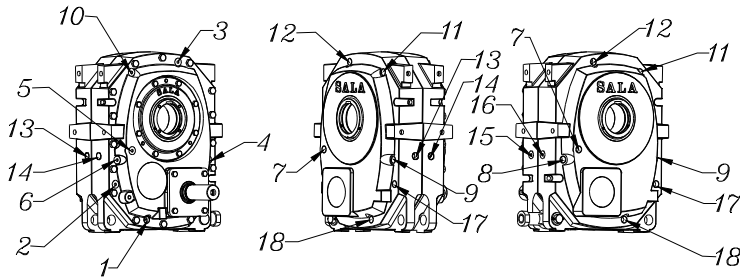

J100 - J190

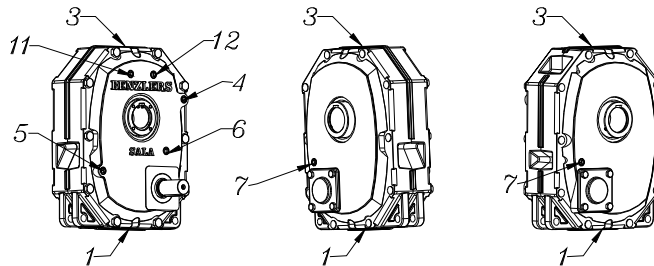

J72

C37004-37.DWG

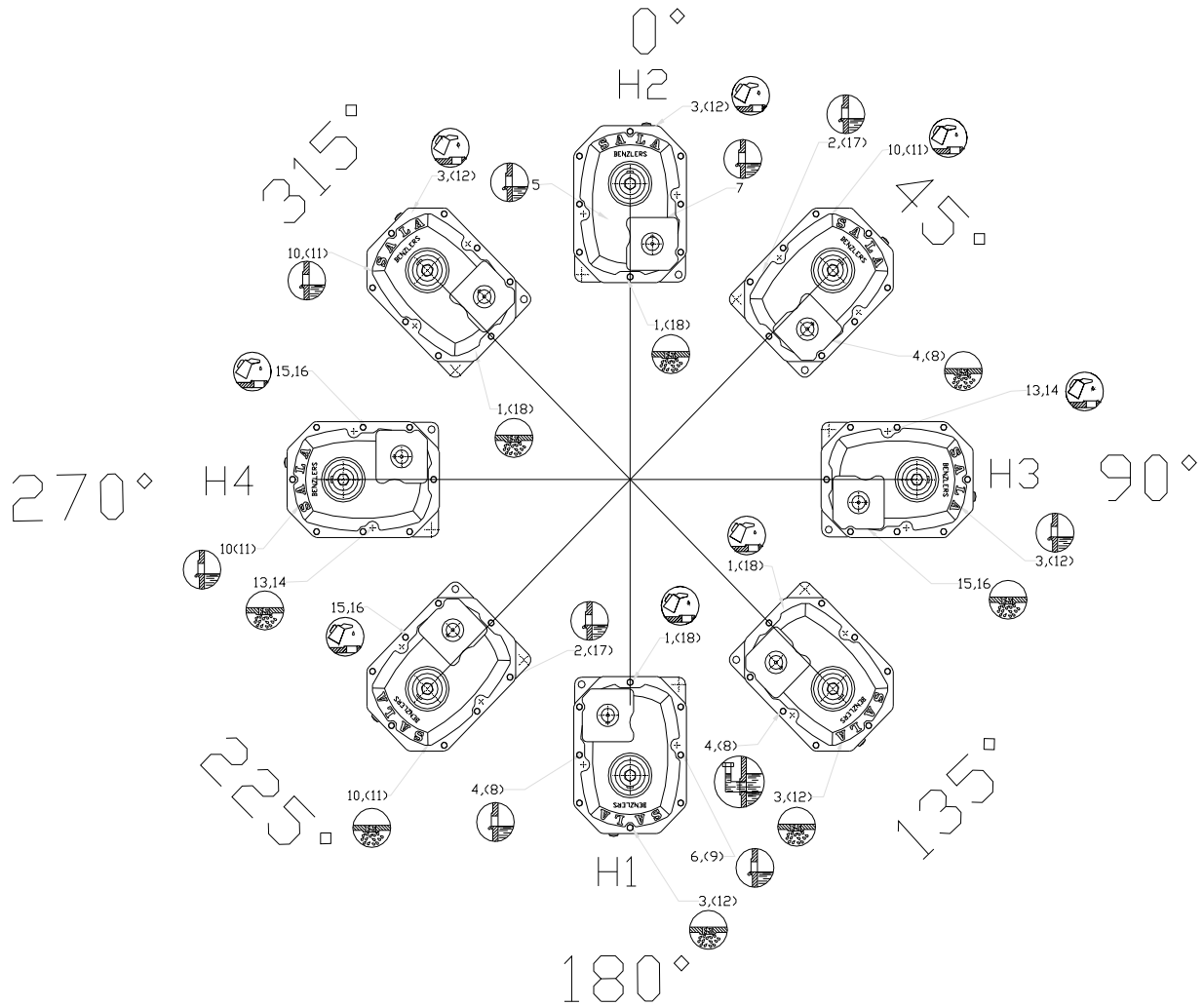

C37004-35.dwg

On J11-32 there is only one oil level plug.

All Benzler-SALA speed reducers are prepared for synthetic oil type Polyalfaolefin.

Note.

Oil of mineral type should not be mixed with oil of syntetic type.

Always check oil level when changing oil.

SALA hollow shaft gears are supplied without lubricant.

KIBO-Mounting

For Correct mounting of speed reducer it is very important that both bushings get the same squeezing force.

1. Mount the inner bushing with the nut in its outer position. The bushing shall be mounted against the shoulder or circlip. Where the shoulder should not exceed inside of nut.
2. Put the key in the keyway.
3. Mount the reducer on the machine shaft and press it against the inner bushing.
4. Mount the outer bushing with the nut in it's inner position. Check that the bushing is not squeezed but the nut is in contact with the shaft sleeve.
5. Mount the washer with it's bolt. Tighten the bolt with correct torque. The inner bushings is now locked.
6. Loosen the bolt, so the outer bushing is loose. Turn the nut on the bushing, in it's outer position.
7. Tighten the bolt once again with correct torque. The outer bushing is now locked. The thicker washer may be changed to the thinner one in order to gain more space at the hollow shaft end. The thinner washer should be tightened with a torque of 25% of the value given in the table below. (only valid for gear size J11-72)
8. Screw the nuts against the hollow shaft by hand, mounting is completed.

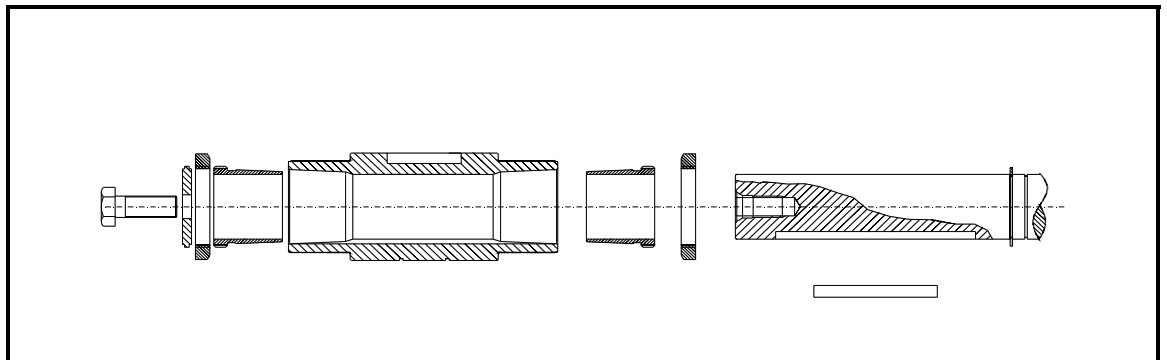

Tightening torque.

Size	D	Screw	Tightening torque. Nm
J12	35	M12	53
J12	45	M16	59
J22	45	M16	130
J22	55	M20	110
J32	55	M20	150
J32	65	M20	120
J52	60	M20	200
J52	75	M20	180
J72	70	M20	290
J72	85	M20	170
J100	100	M24	510
J110	110	M24	380
J125	125	M24	370
J140	140	M30	510
J160	160	M30	430
J190	190	M30	650

Note !

If reducer is mounted in a corrosive environment, ensure machine shaft bushings and nuts are oiled or greased.

Do NOT use lubricants based upon molybdenisulphide.

Dismounting

1. Loosen the bolt and take away the washer.
2. Pull out the outer bushing with the nut, by turning the nut with a adequate tool. Take out the bushing.
3. Press the reducer from the inner bushing with the nut, dismounting is completed.

Installing of shaft sleeve

J100-190 Fig . 1B

Installation kit consists of 2 pcs insert sleeves, 1 pcs special key and 2 stop screws.

1. Fit the insert sleeve (4) on the shaft (1).
2. Line up the key (2) with the keyway (3) in the shaft.
3. Fit the remaining insert sleeve(4) in the shaft sleeve (3).
4. Fit the gear with sleeve on the machine shaft so that the shaft sleeve slides over the insert sleeve..
5. Screw the two stop screws(6) through the shaft sleeve, through the inner insert sleeve and against the machine shaft.
6. Press the outer insert sleeve in position, assemble circlip(3), washer(31) and screw(35).

Fig 1B

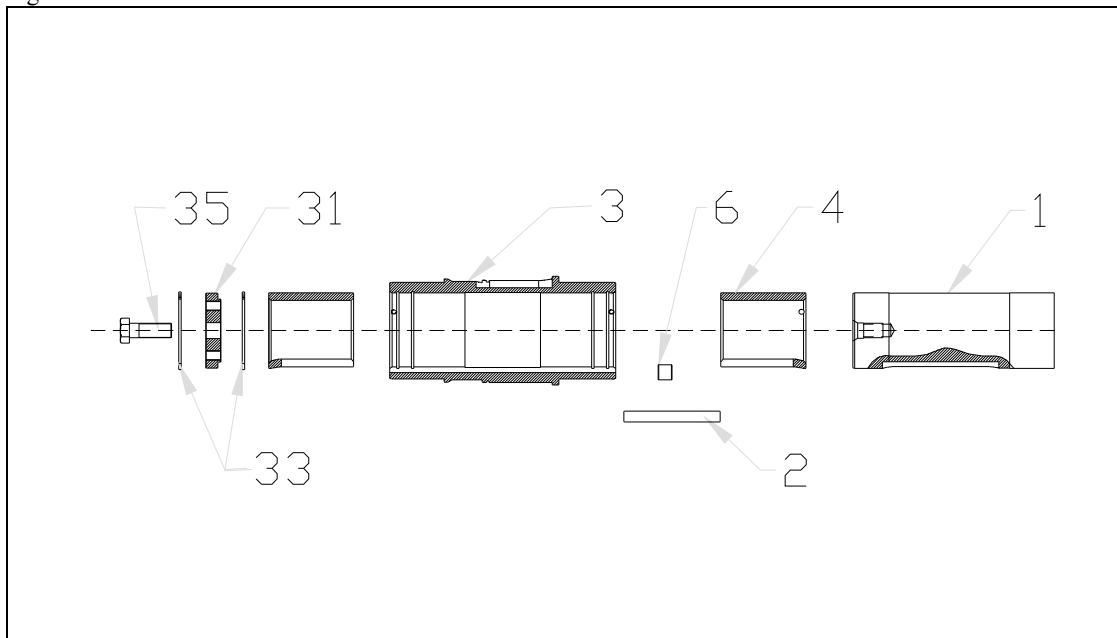

J11-72 Fig 2B

1. Fit the insert sleeve(4) on the machine shaft (1).
2. Line up the key (2) with the keyway in the machine shaft.
3. Fit the remaining insert sleeve (4), the spacer (6) and locking ring (33) in the shaft sleeve (5).
4. Fit the gear unit on the shaft so that the shaft sleeve slides over the insert sleeve.
5. Lock the gear unit by tightening the bolt (35) against the washer (31) and circlip(33) .

Fig 2B

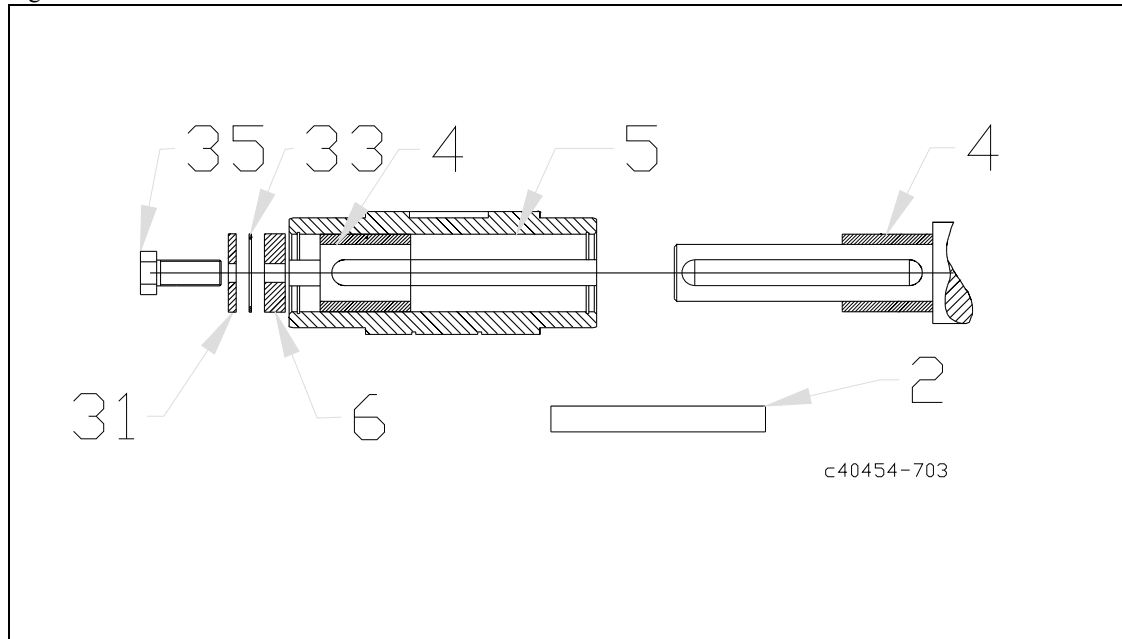

Removing of Gear from Machine Shaft.

J11A-32B, alternative 1.

1. Remove End screw, Washer and Torque arm.
2. Use a Puller of such size that it goes round on the back of gearbox to pull it of the Machine shaft.

J11A-32B, alternative 2.

1. Remove End screw, Washer and Torque arm.
2. Use Benzler dismounting kit (see fig 3.) to remove gear from Machine shaft.

J51A-72B

1. Remove End screw, Washer, Circlip , Spacer (some sizes) and Torque arm
2. Use Benzler dismounting kit (see fig 3.) to remove gear from Machine shaft.

J100-190

1. Remove End screw and Torque arm.
2. Check that Circlip is placed in outer groove.
3. Screw 2 fully threaded Screws into the prethreaded holes in End washer.
4. Turn the two screws diagonally until the gear is removed from Machine shaft.

Fig 3

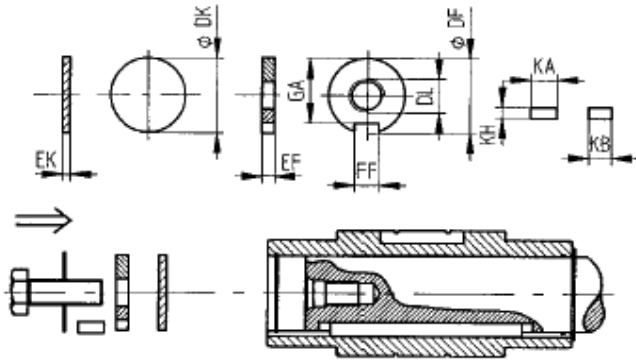

J	DF	DK	DL	EF	EK	FF	GA	KA	KB	KH
12A	35	35	M12	10	6	10	30	20	10	8
12B	45	45	M12	10	6	14	40	20	10	8
22A	45	45	M12	10	6	14	40	20	14	8
22B	55	55	M16	10	6	16	50	20	14	8
32A	55	55	M16	12	6	16	50	25	16	9
32B	65	65	M20	12	6	18	58	25	16	9
52A	60	60	M20	16	6	18	53	25	18	11
52B	75	75	M20	16	6	20	68,5	25	18	11
72A	70	70	M20	20	6	20	62,5	20	20	12
72B	85	85	M24	20	6	22	76	20	20	12

C37004-39.DOC

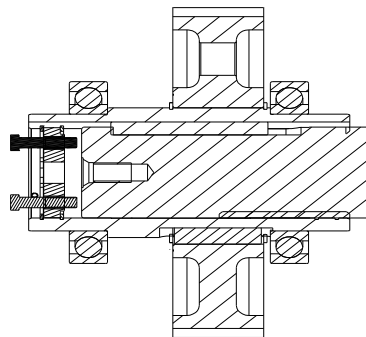
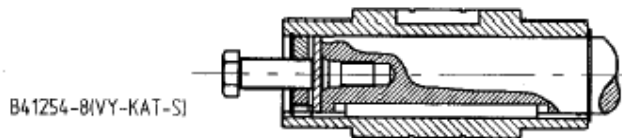

General information about backstop.

Before the backstop is fitted the torque and input speed should be checked against the table.

Torque may reach 2,5 x value shown for brief periods.

See hollow shaft gear against input shaft and decide the direction of rotation of the output shaft:
anticlockwise BV, or clockwise BH.

Always state direction of rotation when ordering gear unit including backstop.

Size	Backstop Type	Max Input torque .Nm	Min Input speed rpm	Max Input speed rpm
J 12A/B	ASNU15EP	75	-	2400
J 22A/B	ASNU17EP	112	-	2300
J 32A/B	ASNU20EP	160	-	2100
J 52A/B	ASNU30EP	500	-	1400
J 72A/B	ASNU35EP	750	-	1200
J100	RSCI40	1600	720	7600
J110	RSCI45	1800	665	6600
J125	RSCI50	2800	610	6100
J140	RSCI60	4700	490	6100
J160	RSCI70	6100	480	4500
J190	RSCI80	9000	450	4000

Instructions for backstop J12-32 Installation Fig.6

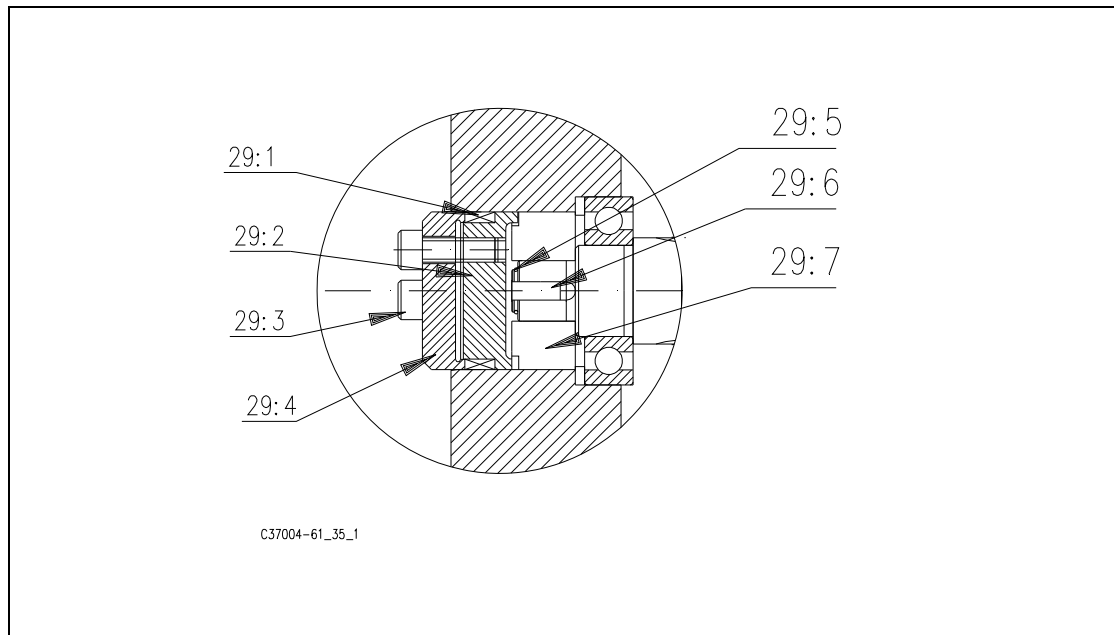

Permissible working temperature in steady operation -30°C $+$ 100°C . Backstop supplied with corrosion protection **DO NOT REMOVE**.

1. Remove the cover (14) from the gear.
2. Decide the direction of rotation for the backstop (29:7) and slide it onto the shaft(1) against the gear casing bearing. The backstop must be slided on and inserted by hand. In no case strong violence may be used. If a small force is required apply it both on inner and outer race in accordance with general bearing assembly.
3. Fit the key (29:6) in the keyway between the shaft (1)and backstop (29:7).
4. Fit the locking ring (29:5).
5. Slide in the backstop bracket (29:2) making sure the lug engages in the slot in the backstop.(29:7)
6. Lubricate the clamp (29:1). NOTE OIL MUST NOT CONTAIN MOLYBDENISULPHIDE.
7. Slide the clamp (29:1) onto the backstop bracket (29:2).
8. Coat at least 5mm of the thread nearest the screw heads (29:3)with thread locking agent.
9. Fit the clamp cover (29:4) using the screws (29:3). Tighten the screws diagonally to the torques given below.

Tightening torque.(29:3)	J12	J22	J32
Nm	17	35	41

**Instructions for backstop J52-72
Installation Fig 9.**

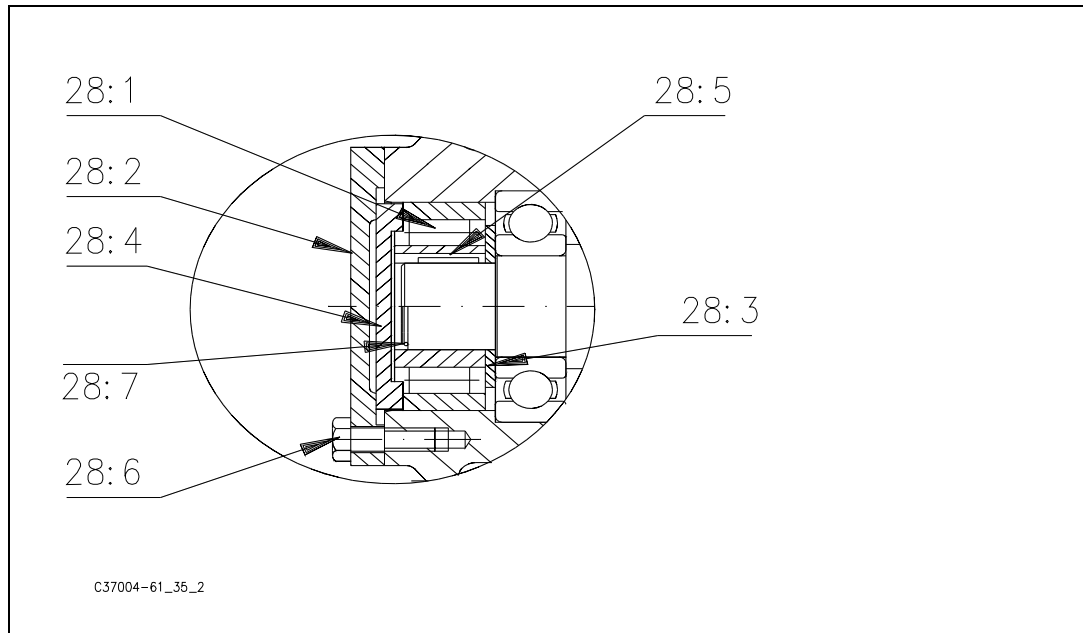

Permissible working temperature in steady operation -30°C $-+100^{\circ}\text{C}$. Backstop supplied with corrosion protection **DO NOT REMOVE**.

1. Remove cover (14) from the gear.
2. Fit the support ring (28:3) against the bearing. (Only applies to J52)
3. Grease the shaft on which the backstop is to be mounted and fit the key (28:5) in the shaft keyway. In case of J72, fit also locking ring (28:7).
4. Determine the direction of rotation of the backstop (28:1) and slide this onto the shaft (1).
5. Fit the key (28:4) in the cover (28:2) and screw cover on the reducer.

Instruction for back stop J100-J190 Assembly se fig 10.

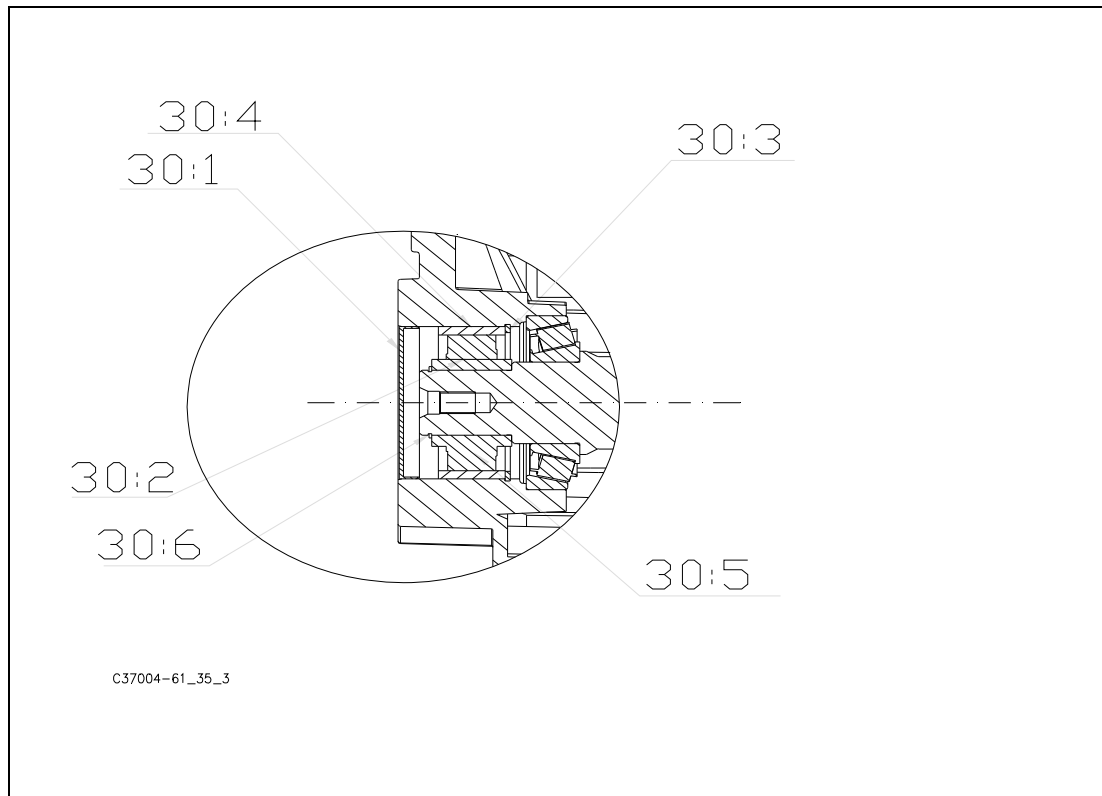

Permissible working temperature in steady operation -30°C $-+100^{\circ}\text{C}$. Backstop supplied with corrosion protection DO NOT REMOVE.

1. Dismantle the cover part (30:1*) from standard reducer.
2. Assembly the snap ring part (30:3*) in gear housing.
3. Grease shaft end where back stop is to be fitted and put Key part (30:2*) into the keyway.
4. Determine direction of rotation and remove outer race part (30:4*) of backstop and fit it gently against the snap ring part (30:3*) in gear housing. (Direction of rotation is changed if back stop is reversed.)
5. Mount the inner part of back stop, part (30:5*) into guiding ring, (ordered separately).
6. Now press by hand the guiding ring with back stop against the outer race, part (30:4*) and push back stop against shaft shoulder.
7. Remove the guiding ring and fit snap ring, part (30:6*) on gear shaft.
8. Fit new cover, part (30:1*), and fill up with oil before starting.

* As shown in spare parts list.

CONTACT US

AUSTRALIA

Radicon Transmission (Australia) PTY Ltd

Australia
Tel: +61 421 822 315

DENMARK

Benzler Transmission A/S

Dalager 1
DK-2605 Brøndby,
Denmark

Tel: +45 36 34 03 00
Fax: +45 36 77 02 42

SWEDEN & NORWAY

AB Benzlers

Porfyrgatan
254 68 Helsingborg
Sweden

Tel: +46 42 18 68 00
Fax: +46 42 21 88 03

UNITED KINGDOM

Radicon Transmission UK Ltd

Unit J3
Lowfields Business Park,
Lowfields Way, Elland
West Yorkshire, HX5 9DA

Tel: +44 1484 465 800
Fax: +44 1484 465 801

EUROPE

Benzler TBA BV

Jachthavenweg 2
NL-5928 NT Venlo

Germany
Tel: 0800 350 40 00
Fax: 0800 350 40 01

Italy
Tel: +39 02 824 3511

Netherlands & the rest of Europe
Tel: +31 77 324 59 00
Fax: +31 77 324 59 01

FINLAND

Oy Benzler AB

Vanha Talvitie 3C
FI-00580 Helsingfors,
Finland

Tel: +358 9 340 1716
Fax: +358 10 296 2072

THAILAND

Radicon Transmission (Thailand) Ltd

700/43 Moo 6
Amata Nakorn Industrial Estate
Tumbol Klongtumru
Muang,
Chonburi
20000
Thailand

Tel: +66 3845 9044
Fax: +66 3821 3655

USA

Radicon Drive Systems, Inc.

2475 Alft Lane
Elgin
Chicago
Illinois
60124
USA

Tel: +1 847 593 9910
Fax: +1 847 593 9950

INDIA

Elecon. Engineering Company Ltd.

Anand Sojitra Road
Vallabh Vidyanagar
388120 Gujarat
India

Tel: +91 2692 236513

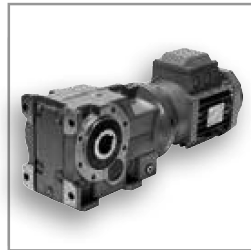
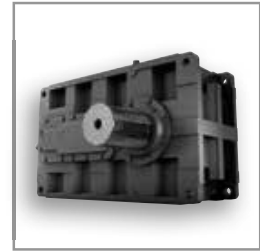
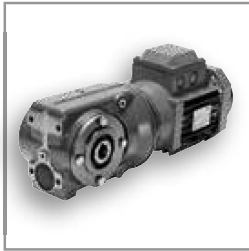
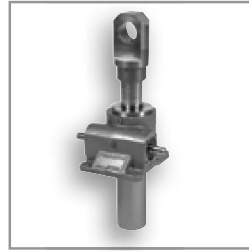

benzlers^{⚙️}
radicon^{⚙️}

Benzlers

Denmark +45 36 340300
Finland +358 9 3401716
Germany +49 800 3504000
Italy +39 02 824 3511
Sweden +46 42 186800
The Netherlands +31 77 3245900
www.benzlers.com

Radicon

Thailand +66 38459044
United Kingdom +44 1484 465800
USA +1 847 5939910
www.radicon.com