

benzlers 
with you at every turn

Roloid Gear Pump
Installation & Maintenance



radicon 
with you at every turn

IRGP-2.00GB1211

PRODUCTS IN THE RANGE

Serving an entire spectrum of mechanical drive applications from food, energy, mining and metal; to automotive, aerospace and marine propulsion, we are here to make a positive difference to the supply of drive solutions.

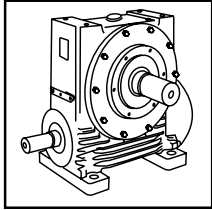

Series A
Worm Gear units
and geared motors
in single & double
reduction types

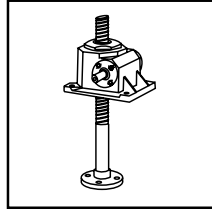

Series BD
Screwjack worm
gear unit

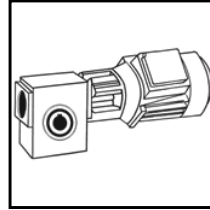

Series BS
Worm gear unit

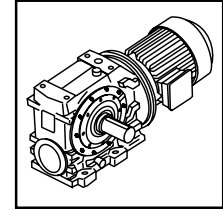

Series C
Right angle drive
helical worm geared
motors & reducers

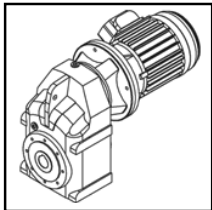

Series F
Parallel angle helical
bevel helical geared
motors & reducers

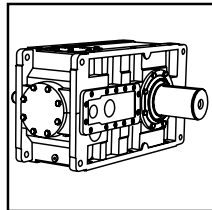

Series G
Helical parallel shaft
& bevel helical right
angle drive gear
units

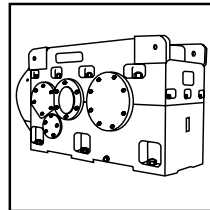

Series H
Large helical parallel
shaft & bevel helical
right angle drive units

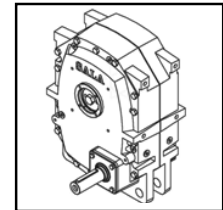

Series J
Shaft mounted
helical speed
reducers

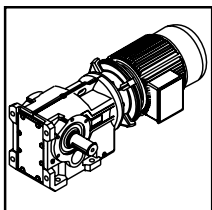

Series K
Right angle helical
bevel helical geared
motors & reducers

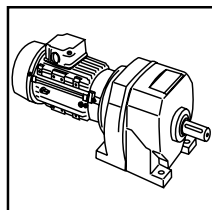

Series M
In-line helical geared
motors & reducers

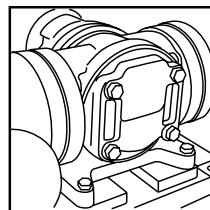

Roloid Gear Pump
Lubrication and fluid
transportation pump

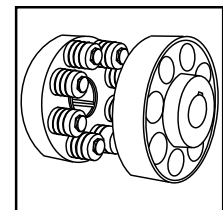

**Series X
Cone Ring**
Pin and bush
elastomer coupling

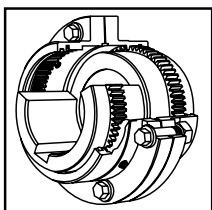

**Series X
Gear**
Torsionally rigid,
high torque coupling

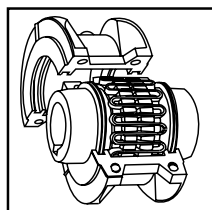

**Series X
Grid**
Double flexing steel
grid coupling

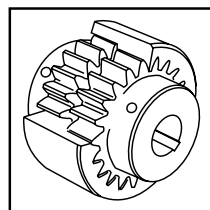

**Series X
Nylon**
Gear coupling with
nylon sleeve

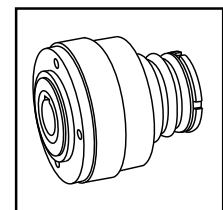

**Series X
Torque Limiter**
Overload protection
device



We offer a wide range of repair services and many years experience of repairing demanding and highly critical transmissions in numerous industries.

We can create custom engineered transmission solutions of any size and configuration.



IMPORTANT

Product Safety Information

General - The following information is important in ensuring safety. It **must** be brought to the attention of personnel involved in the selection of the equipment, those responsible for the design of the machinery in which it is to be incorporated and those involved in its installation, use and maintenance.

The equipment will operate safely provided it is selected, installed, used and maintained properly. As with any power pumping equipment **proper precautions must** be taken as indicated in the following paragraphs, to ensure safety.

Potential Hazards - these are **not** necessarily listed in any order of severity as the degree of danger varies in individual circumstances. It is important therefore that the list is studied in its entirety:-

- 1) Fire/Explosion
 - (a) Oil mists and vapour may be generated. It is therefore dangerous to use naked lights in the proximity of the pump openings, due to the risk of fire or explosion.
 - (b) In the event of fire or serious overheating (over 300 °C), certain materials (rubber, plastics, etc.) may decompose and produce fumes. Care should be taken to avoid exposure to the fumes, and the remains of burned or overheated plastic/rubber materials should be handled with rubber gloves.
- 2) Guards - Rotating shafts and couplings must be guarded to eliminate the possibility of physical contact or entanglement of clothing. It should be of rigid construction and firmly secured.
- 3) Noise - The machinery may produce noise levels which are damaging to the hearing with prolonged exposure. Ear defenders should be provided for personnel in these circumstances. Reference should be made to the Department of Employment Code of Practice for reducing exposure of employed persons to noise.
- 4) Lifting - Where provided (on larger units) only the lifting points or eyebolts must be used for lifting operations (see maintenance manual or general arrangement drawing for lifting point positions). Failure to use the lifting points provided may result in personal injury and/or damage to the product or surrounding equipment. Keep clear of raised equipment.
- 5) Lubricants and Lubrication
 - (a) Prolonged contact with lubricants can be detrimental to the skin. The manufacturer's instruction must be followed when handling lubricants.
 - (b) The lubrication status of the equipment must be checked before commissioning. Read and carry out all instructions on the lubricant plate and in the installation and maintenance literature. Heed all warning tags. Failure to do so could result in mechanical damage and in extreme cases risk of injury to personnel.
- 6) Electrical Equipment - Observe hazard warnings on electrical equipment and isolate power before working on the unit or associated equipment, in order to prevent the machinery being started.
- 7) Installation, Maintenance and Storage
 - (a) In the event that equipment is to be held in storage, for a period exceeding 6 months, prior to installation or commissioning, application engineering must be consulted regarding special preservation requirements. Unless otherwise agreed, equipment must be stored in a building protected from extremes of temperature and humidity to prevent deterioration. The rotating components (gears and shafts) must be turned a few revolutions once a month (to prevent bearings brinelling).
 - (b) External pump components may be supplied with preservative materials applied, in the form of a "waxed" tape overwrap or wax film preservative. Gloves should be worn when removing these materials. The former can be removed manually, the latter using a suitable solvent. Preservatives applied to the internal parts of the pump do not require removal prior to operation.
 - (c) Installation must be performed in accordance with the manufacturer's instructions and be undertaken by suitably qualified personnel.
 - (d) Before working on the pump or associated equipment, ensure that the load has been removed from the system to eliminate the possibility of any movement of the machinery and isolate power supply. Where necessary, provide mechanical means to ensure the machinery cannot move or rotate. Ensure removal of such devices after work is complete.
 - (e) Ensure the proper maintenance of units in operation. Use only the correct tools and approved spare parts for repair and maintenance. Consult the Maintenance Manual before dismantling or performing maintenance work.
- 8) Hot Surfaces and Lubricants
 - (a) During operation, pumps may become sufficiently hot to cause skin burns. Care must be taken to avoid accidental contact.
 - (b) After extended running the pump may reach temperatures sufficient to cause burns. Allow equipment to cool before servicing or performing adjustments.
- 9) Selection and Design
 - (a) The driving and pipe work system must be correctly selected to ensure that the complete machinery installation will perform satisfactorily, avoiding system critical speeds, cavitation, blockages, vibration, etc.
 - (c) The equipment must not be operated in an environment or at speeds, powers, flow rates or suction lifts beyond those for which it was designed.
 - (d) As improvements in design are being made continually the contents of this catalogue are not to be regarded as binding in detail, and drawings and capacities are subject to alterations without notice.

The above guidance is based on the current state of knowledge and our best assessment of the potential hazards in the operation of the pump. Any further information or clarification required may be obtained by contacting our Application Engineers.

Section	Description	Page No
-	Declaration of Conformity / Incorporation	3
1	General Information	4
2	External Protection	4
3	Reading the Nameplate	4
4	The  Marking	4
5	Installation	
	5.1 Safety Warning	5
	5.2 Prior to Installation	5
	5.3 Lifting	5
	5.4 Fitting of Components to Pump Input Shaft	5
	5.5 Mounting to Base Foundation or Machine Flange	6
	5.6 Mounting to Pipe Work	6
	5.7 Direction of Rotation	7
	5.8 Special Instructions for use in a Potentially Explosive Atmosphere	7
6	Lubrication	7
7	Motor Connections	8
8	Starting Up	8
9	Operation	
	9.1 Noise	8
	9.2 General Safety	8
	9.3 Gear units for use in a potentially explosive atmosphere	8
10	Maintenance	
	10.1 Prior to any Maintenance Operations	9
	10.2 Replacing Oil Seals	9
	10.3 Bearings	9
	10.4 Cleaning	9
11	Fault Diagnosis	10
Appendix		
1	Shaft Alignment	11
2	Parts List	12

Safety Warning Symbols



Electrical Hazard
Could result in death or serious injury



Danger
Could result in serious, slight or minor injuries



Danger (Touch Hazard)
Could result in death or serious injury



Damaging Situation
Could result in damage to gear unit or driven machinery



Important notes on Explosion Protection



Cleaning
Periodic cleaning necessary

Declaration of Conformity

We hereby declare that Roloid Gear Pumps have been designed in accordance with the following Directives and Standards.

- The Machinery Directive 2006/42/EC
- EN ISO 12100-1,2 The Safety of Machinery
- Conforms to all other harmonised standards, tests, and specifications, (In as much as they apply to our products)

Declaration of Incorporation

According to Machinery Directive 2006/42/EC Annex IIB

This product must not be put into service until the machinery into which it is to be incorporated has been declared in conformity with the provisions of the machinery directive 2006/42/EC.

The equipment shall only be loaded within the framework of our recommendations, and installed and operated in accordance with our installation and maintenance instructions.

The company hereby draws attention to the dangers of improper use of this equipment and particularly warns users against operating with inadequate guarding of rotating parts and the use of naked lights in close proximity to the equipment.

We will, upon a reasoned request from national authorities, provide any relevant information on its products.

Warranty Conditions

We warrant our products to be free of defects for a period of 12 months from the date the product is installed to a maximum of 18 months from the date of shipment.

The warranty will only be valid if the product is loaded within the framework of our recommendations and installed and operated in accordance with our installation and maintenance instructions.

The warranty is limited to the repair or replacement of defective product or part which is returned to our factory after notification of failure.

We shall only be liable for the repair and replacement of the product and shall not be liable to any consequential damages resulting from a defective or non-conforming product.

Scope

The following instructions will help you achieve a safe and satisfactory installation of your gear pump ensuring the best possible conditions for long and trouble free operation.

Gear pumps are often supplied modified to suit specific customer requirements, these instructions shall be supplementary to any information contained on certified arrangement drawing or separate instructions supplied with the equipment.

1. General Information

The following instructions will help you achieve a satisfactory installation of your Roloid gear pump,

Roloid pumps are of simple design using a minimum number of moving parts ensuring that if correctly installed will provide the best possible conditions for a long and trouble free operation.

All units are tested and checked prior to despatch, a great deal of care is taken in packing and shipping arrangements to ensure that the unit arrives at the customer in the approved condition.

2. External Protection

All Roloid gear pumps are provided with protection against normal weather conditions. Where pumps are to operate in extreme conditions, or where they are to stand for long periods without running, e.g. during plant construction, consult our application engineers so that arrangements for adequate protection can be made.

3. Reading the Nameplate



3.1 Unit Identification

When requesting further information, or service support quote the following information from the nameplate:

- Pump Size and Rotor
- Serial number / Year of Manufacture

3.2 Pump Unit Rating

The flow capacity rating (litres/min) pump speed (rpm) and operating pressure are marked on the nameplate – Check that these details match the requirements of the machine prior to installation

3.3 Group/Category

Only pumps specifically selected for use in a potentially explosive atmosphere will be factory engraved with the Ex group/category.

4. The Marking



Roloid pumps with  marking are specifically selected for use as a component of an industrial system operating in a potentially explosive atmosphere

Provided the pump is correctly selected, Ex marked and installed in accordance with these instructions it will comply with the EU directive 94/9EC (ATEX 100a)

Pumps must be selected by our application engineers for use only in the following potentially explosive atmospheres:

Hazard Group II Cat 2 (zones 1 & 21) or Group II Cat 3 (zones 2 & 22) Temperature class T3, T4 or T5 Motors, couplings, or any other equipment fitted to the pump must also comply with this directive.

If the pump is supplied as a motorised package it is important to check the nameplates of both the pump and the motor (or any other equipment fitted) corresponds with the classification of the potentially explosive atmosphere in which the unit is to be installed.



5. Installation

5.1. Safety Warning

WARNING!



CAUTION



The customer shall be responsible for the proper use of articles supplied by the company, particularly rotating shafts between the driving members, and the provision of safety guarding.

The company shall not be responsible for any injury or damage sustained as a result of the improper use of the articles supplied.

Attention is hereby drawn to the danger of using naked lights in proximity of Roloid pumps supplied by the company, and the company shall not be liable for any claim for injury or damage arising from any action in contravention of this warning.



5.2. Prior to Installation

- 5.2.1. Check the pump unit has not been damaged.
- 5.2.2. Check the pump unit / motor nameplate matches the requirements of the machine the pump unit is to be installed on.
- 5.2.3. Thoroughly clean the shaft and mounting surfaces that are to be used of anti-corrosion agents using a commercially available solvent. Ensure solvent does not make contact with the oil seals.



CAUTION

5.3. Lifting

- 5.3.1. Larger pump units are fitted with lifting eyebolts - Use only the lifting points provided.

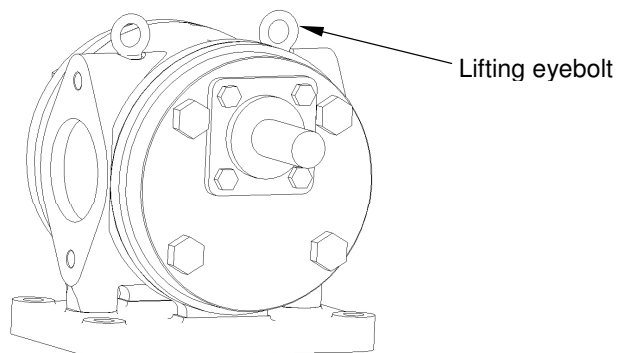

5.4. Fitting of Components to the Pump Drive Shaft

- 5.4.1. Ensure shaft extension, bores & keys etc are cleaned.
- 5.4.2. The input shaft extension diameter tolerance is to ISO tolerance k5 (for shaft diameter $\leq 12.5\text{mm}$) and m6 (for shaft diameter $> 12.5\text{mm}$) and the fitted components should be to ISO tolerance M7 (for bore diameter $\leq 50\text{mm}$) and K7 (for bore diameter $> 50\text{mm}$).
- 5.4.3. Items (such as gears, sprockets, couplings etc) should not be hammered onto these shafts since this would damage the shaft support bearings.
- 5.4.4. Bores of Metallic Items may be heated to 80/100 °C to aid assembly.



CAUTION



5.5. Mounting to Base Foundation or Machine Flange



5.5.1. Ensure the base foundation or machine flange mounting surface is flat¹, vibration absorbing and torsionally rigid. (¹ Maximum permissible flatness error for the mounting surface is 0.12mm)



5.5.2. Align the pump unit with the driving shaft or motor shaft (see Appendix 1).

Note: It is important to ensure when aligning unit on a base plate or flange that all machined mounting points are supported over their full area.

Check that all mounting points are fully supported and adjust if necessary by using steel packing's. If steel packing's are used between the equipment and base plate, these packing's should be placed at either side and as close to the foundation bolt as possible.

During final bolting ensure the pump unit, base plate or flange is not distorted as this could cause strains in the pump housing resulting alignment errors of shafts and rotors.

Secure using heavy duty bolts to ISO grade 8.8 minimum.

Torque tighten the bolts to value's specified in Table 1 except for aluminium flange motors, Bolt torques for aluminium flanged motors should be 75% of the values listed below:

Fit shaft /coupling guards where appropriate.

Bolt Size	Torque
M6	10 Nm
M8	25 Nm
M10	50 Nm
M12	85 Nm
M16	200 Nm
M20	350 Nm
M24	610 Nm
M30	1220 Nm
M36	2150 Nm

Table 1

5.6. Mounting to Pipe Work



5.6.1. It is recommended that suitable priming facilities i.e. U-shaped bends are installed in the pipe work at the suction side to prevent the pump starting dry, a filling port should be provided at the highest point of the suction pipe work for initial priming, where the pump ports are to be mounted vertically a non-return valve (or similar) should be incorporated in the suction line.



5.6.2. It is essential priming facilities are provided where a suction lift of greater than 2.4 Metres is required or the pump is to be used in a potentially explosive (ATEX) atmosphere



5.6.3. If the pump is to be connected to rigid pipe work ensure the pipes and fittings are made correctly to size so that errors in the pipe work when bolted to the pump do not impose strains in the pump housing resulting alignment errors of shafts and rotors.

5.6.4. For pumps operating at differential pressures of over 13 Bar (20 Bar Maximum) it is recommended that the pipe flanges are jointed as shown below:

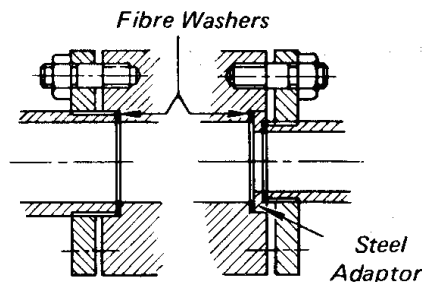

Types of joints recommended for pressures over 13 Bar
(Fibre Washers and Steel Adaptors are not supplied)



5.7. Direction of Rotation



5.7.1. Roloid pumps may be operated in either direction of rotation. If direction of rotation is changed the direction of flow will be reversed,



CAUTION

5.7.2. The direction of rotation and flow relationship are shown below:

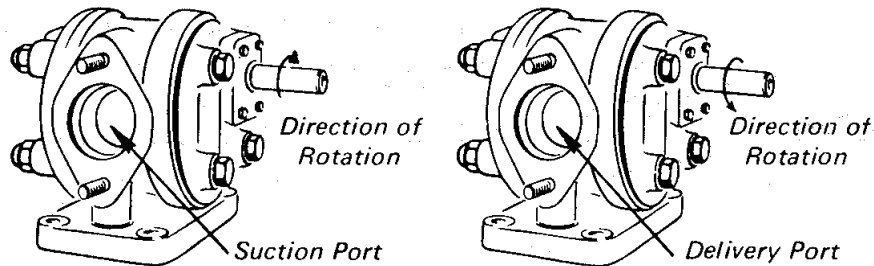

5.8. Special Instructions for use in a Potentially Explosive Atmosphere

- 5.8.1. If the pump unit has been damaged in transit do not use. (Remove all transport fixtures and packing's prior to start up)
- 5.8.2. Check nameplate of unit corresponds with the sites potentially explosive atmosphere classification.
- 5.8.3. Make sure no potentially explosive atmosphere exists during installation.
- 5.8.4. Make sure that pump unit is sufficiently ventilated with no external heat input – cooling air temperature should not exceed 40°C
- 5.8.5. Check motors, couplings or any other equipment to be fitted to the pump unit has ATEX approval. Check information listed on the nameplates correspond to the environmental conditions of the site.
- 5.8.6. Ensure the pump is not subjected to any loading greater than those marked on the nameplate.
- 5.8.7. Pumped media must contain a lubricant and not contain any solid matter, Petrol and Solvents are not permitted.
- 5.8.8. **For units operated with inverter drives**, check motor suitability for use with the inverter. Ensure that the inverter parameters do not exceed those of the motor.
- 5.8.9. **For belt driven units**, check all belts fitted are of sufficient electrical leakage resistance. ($< 10^9 \Omega$).
- 5.8.10. Ensure the pump unit and other equipment fitted is electrically grounded (Earthed).
- 5.8.11. Ensure pump cannot be run dry (dry running is not permissible), priming facilities must be provided (See section 5.6)
- 5.8.12. Check and adjust safety guards and covers so that there is no ignition source from sparks that may be thrown by moving parts making contact with guards etc.
- 5.8.13. Ensure safety guards and covers etc... are designed dust tight or designed to prevent a build up of dust deposits from forming when the unit is used in dust atmosphere classification areas (Zone 21 or Zone 22).

6. Lubrication



- 6.1. Roloid gear pumps are completely self lubricating using the fluid being pumped for lubricating purposes. It is essential that the pumped fluid contains a suitable lubricant and is kept free from water content or impurities.



7. Motor Connections

To mains:



7.1. Connection of the electric motor to the mains supply should be made by a qualified person. The current rating of the motor will be identified on the motor plate, and correct sizing of the cables to electrical regulations is essential.

Motor terminal connection:

7.2. The motor should be wired in accordance with the manufacturers instructions.

8. Starting Up



8.1. Prior to Starting Up



8.1.1. Ensure all operational safety devices are in place (i.e. guards fitted). Check and adjust guards and covers so that there is no ignition source from sparks that may be thrown by moving parts making contact with guards etc. Ensure coupling guards, covers etc are dust tight or are designed in such a way that a build up of dust deposits cannot form when the unit is used in Zone 21 & Zone 22 classification areas.



8.1.2. Check the pump unit has been assembled correctly for the required direction flow and shaft rotation.

8.1.3. Remove any temporary safety devices/locks fitted to prevent personal injury during assembly.

8.1.4. Starting up should only be performed or supervised by suitably qualified personnel.



Caution: Any deviation from normal operating conditions, (increased temperature, noise, Vibrations, power consumption etc) suggest a malfunction, inform maintenance personnel immediately.

9. Operation

9.1. Noise



Check the noise level of the pump and surrounding equipment
Ear protection should be worn when working in close proximity of the pump when the noise level exceeds 85db(A)

9.2. General Safety



Potential hazards which can be encountered during installation, maintenance and operation of pump units is covered in greater detail in the product safety page at the front of this booklet.

Advice is also given on sensible precautions which need to be taken to avoid injury or damage.

PLEASE READ!



9.3. Pump Units for Use in a Potentially Explosive Atmosphere

After 1 hour of operation check the pump surface temperature. The temperature should not exceed the values shown in the table below, If the temperature exceeds this limit, shut down immediately and contact our application engineers

Temperature Class	Max Temperature
T3	200 °C
T4	135 °C
T5	100 °C



10. Maintenance



10.1. Prior to any maintenance operations

- 10.1.1. De-energise the drive and secure against un-intentional switch on.
- 10.1.2. Wait until the unit has cooled down – Danger of skin burns & pressure build up.

10.2. Replacing Oil Seals



Periodically worn oil seals may require replacement

These instructions apply only to pump units fitted with rubber lip type seals, (for units fitted with mechanical seals consult the seal manufacturer's instructions)



- 10.2.1. Place a tray under the pump unit to collect any spillage and remove the pump from the machine and pipe work. Warning take care when loosening fastenings as there may be a pressure build up within the pump which may cause fluid to eject.
- 10.2.2. Drain all internal fluid from the pump unit. Note: it is recommended that the fluid in the pump should be slightly warm, (40-50 °C) when drained.
- 10.2.3. Remove the seal housing (1) from the pump and remove the worn seals, clean away any sealant and degrease the housing facings (5). Warning rubber gloves should be worn when handling worn oil seals
- 10.2.4. Fit new seals:
 - Apply *grease to the seal (2) lip and outer ring diameter and fit the first seal into the housing as shown below, pack the internal cavity (3) with *grease.
 - Fit the second seal (4) into the seal housing using the same procedure as above.
 - Apply a suitable **liquid gasket to the housing facing (5), fit the seal and housing assembly to the pump taking care not to damage the seal lips, tighten the housing bolts (6) to the torque shown in table 1 (page 5), wipe away any excess grease or gasket material.

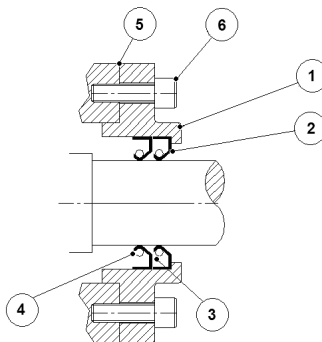

* Use a high temperature NLGI grade 2 grease

** Liquid gasket material – Loctite 5366 or equivalent High Performance Clear Silicone



10.3. Bearings

- 10.4.1 For Ex marked units bearings should be checked after 5 years operation, and replaced by the manufacturer (if necessary)



10.4. Cleaning

- 10.4.1. With the drive stationary, periodically clean any dirt or dust from the pump unit and the electric motor cooling fins and fan guard to aid cooling.
- 10.4.2. Ensure any dust build up does not exceed 5mm (maximum)





11. Fault diagnosis

11.1. Pump Unit Problems:

Symptom	Possible Causes	Remedy
Not Enough or No Liquid is Delivered	Lack of Prime	Fill the pump and its suction pipe completely with the liquid being handled, Bleed the pump and piping to remove air.
	Pump Drive is Interrupted or Speed is Too Low	Check drive coupling and motor connection
	Discharge Head too High	Check discharge line for blockages. Check that valves and other safety devices are working correctly, Check that the size and design of the delivery line meets the specification of the pump
	Suction Lift Too High	Check suction line for blockages. Check that the size and design of the suction line meets the specification of the pump
	Wrong Direction of Rotation	Check and correct as detailed in section 5.7
	Filter Blockage	Check filter elements, clean or replace.
	Fluid or Air Leakage	Check for leaks in the pipe work and connection flanges, Replace worn gaskets & seals as appropriate
Discharge Pressure is Too Low	Suction Pipe not Fully Submerged	Check fluid reserve level or pipe work design
	Speed is Too Low.	Check drive speed is appropriate for the duty
	Gas or Vapour in the system.	Bleed the pump and piping to remove the air from the system
	Worn Pump Internal Parts.	Contact our Sales Engineers
	Worn Gaskets or Seals	Replace or Contact our Sales Engineers
Cavitation (excessive noise)	Obstruction in the Suction line	Check and clear suction line of any blockages
	Suction pipe not fully submerged	Check fluid reserve level or pipe work design
	Pumped Fluid Contains Air	Check the system design - rid the fluid of air
Pump Overloads the Drive	Suction Lift Too High	Check suction line for blockages. Check that the size and design of the suction line meets the specification of the pump
	Discharge Head Too High	Check discharge line for blockages. Check that valves and other safety devices are working correctly, Check that the size and design of the delivery line meets the specification of the pump
	Speed Too High	Check drive speed is appropriate for the duty
	Pump Housing Distorted	Check the connection to mounting flange or base foundation and pipe work comply with sections 5.5 and 5.6
Excessive Vibration or Noise	Pump Drive Shaft Misalignment	Check drive shaft connection is correctly aligned (see appendix 1)
	Gas or Vapour in the system.	Check the tightness of the pipe work fasteners Bleed the pump and piping to remove the air from the system
	Pump Drive Shaft Misalignment	Check drive shaft connection is correctly aligned (see appendix 1)
	Non Rigid Foundation	Check foundation design and revise as appropriate
	Worn Pump Internal Parts.	Contact our Sales Engineers
Excessive Fluid or Pump Temperature	Worn Gaskets or Seals	Replace or Contact our Sales Engineers
	Suction Lift Too High	Check suction line for blockages. Check that the size and design of the suction line meets the specification of the pump
	Debris in the Fluid	Check filters for blockage, Check pump bores and clean away any debris Check for damage to the rotor teeth - Contact our sales engineers
Excessive Fluid or Pump Temperature	Elimination of Internal Rotor Clearance	This is indicative of bearing wear - Contact our sales engineers.
	Closed or Sticking Valve	Check all valves are correctly set and working.

Any further information or clarification required may be obtained by contacting our sales office, Please see contact details at the back of this booklet.

When contacting our sales office please have the following information available:

- Nameplate data (complete)
- Type and extent of the problem encountered
- The time and the circumstances the problem occurred
- A possible cause



Shaft Alignment

Errors of alignment fall into categories of Angularity (fig 1) and Eccentricity (fig 2) or a combination of both, errors of angularity should be checked and corrected before the errors of eccentricity

Errors of Angularity

Errors of angularity can be checked using the following method:

Place a mark on both driving and driven hubs and measure the gap between them adjacent to the marks using a block gauge and feelers at position 1 (see fig 3) then rotate both shafts together a quarter turn keeping the marks aligned and take a another measurement at position 2, further measurements should be taken at positions 3 and 4. The difference between readings at position 1 and 3 can be used to calculate the error in the vertical plane and difference between positions 2 and 4 should be used to calculate the error in the horizontal plane.

The errors of angularity across the coupling diameter can be calculated in both the vertical and horizontal planes,

The maximum error of angularity should be checked and adjusted to be within the coupling manufacturer's recommendations.

If the coupling faces are perfectly true then a stationary method can be used to check the errors of angularity:

Keeping both shafts stationary and take the horizontal and vertical measurements at the four positions (see fig 3)

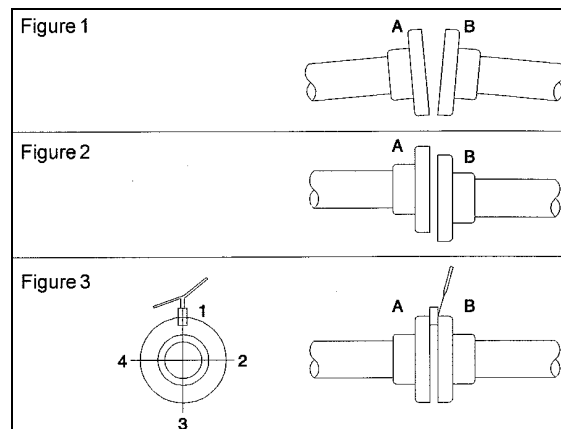

Errors of Eccentricity

Errors of eccentricity require measurements to be taken in the radial direction, the simplest and most convenient method* is to securely attach a dial indicator to one of the coupling hubs (as shown in fig 4) and rotate the hub taking measurements at four points as shown, the difference between measurement points 1 and 3 represent the vertical eccentricity and the difference between points 2 and 4 represent horizontal eccentricity.

The maximum error of eccentricity should be checked and adjusted to be within the coupling manufacturer's recommendations.

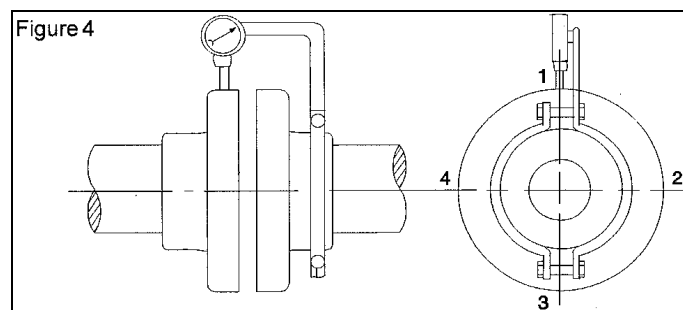

**More accurate alignment measuring processes such as laser alignment should be used when available*



Parts List

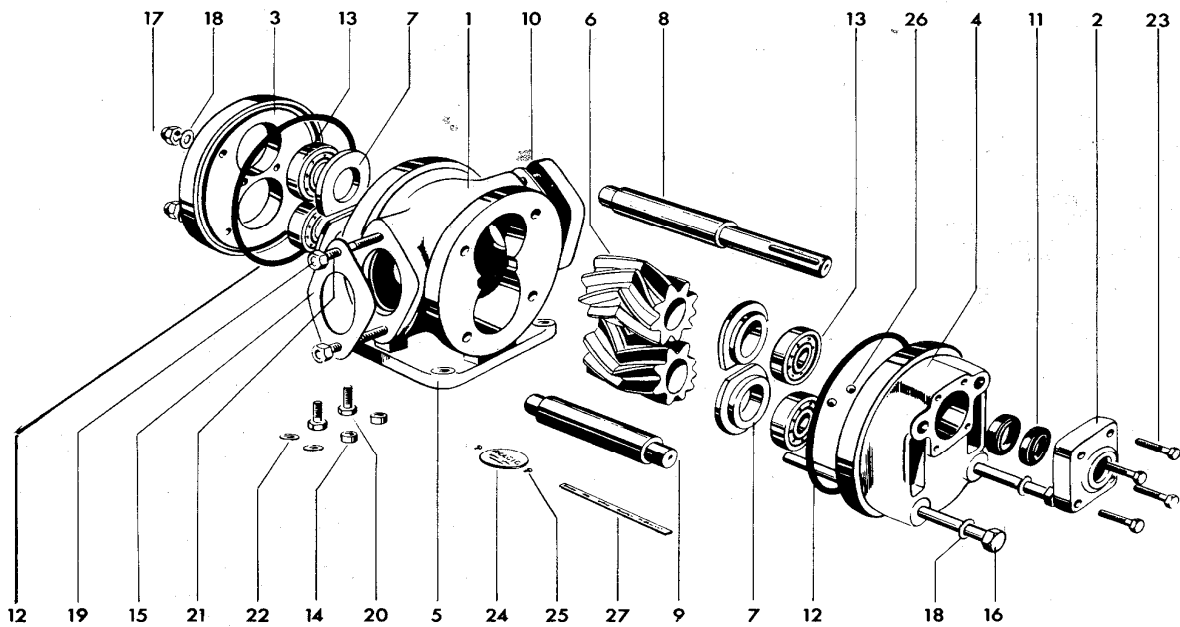

1	Body	10	Pipe Flange (x2)	+19	Pipe Flange Fastenings
2	End Cover (Oil Seal)	11	Oil Seal (x2)	20	Foot Fastenings
3	End Cover (Non Driving)	12	Sealing O'Rings (x2)	+21	Pipe Flange Fastenings
4	End Cover (Driving)	13	Bearings (set of 4)	22	Foot Fastenings
5	Foot	14	Ring Dowels (x2)	23	Cover Fastenings
6	Rotors (set of 4)	15	Jointing (x2)	24	Nameplate
7	Adaptors (set of 4)	*16	Body Fastenings	25	Nameplate Fastenings
8	Driving Shaft	*17	Body Fastenings	26	Ball Valves
9	Driven Shaft	18	Sealing Washers	27	Rotation Plate

* Body Bolts and Dome Nuts are replaced by Setscrews on some models

+ Studs and Nuts replaced by Setscrews on some models

CONTACT US

AUSTRALIA

Radicon Transmission (Australia) PTY Ltd

Australia
Tel: +61 421 822 315

DENMARK

Benzler Transmission A/S

Dalager 1
DK-2605 Brøndby,
Denmark

Tel: +45 36 34 03 00
Fax: +45 36 77 02 42

SWEDEN & NORWAY

AB Benzlers

Porfyrgatan
254 68 Helsingborg
Sweden

Tel: +46 42 18 68 00
Fax: +46 42 21 88 03

UNITED KINGDOM

Radicon Transmission UK Ltd

Unit J3
Lowfields Business Park,
Lowfields Way, Elland
West Yorkshire, HX5 9DA

Tel: +44 1484 465 800
Fax: +44 1484 465 801

EUROPE

Benzler TBA BV

Jachthavenweg 2
NL-5928 NT Venlo

Germany
Tel: 0800 350 40 00
Fax: 0800 350 40 01

Italy
Tel: +39 02 824 3511

Netherlands & the rest of Europe
Tel: +31 77 324 59 00
Fax: +31 77 324 59 01

FINLAND

Oy Benzler AB

Vanha Talvitie 3C
FI-00580 Helsingfors,
Finland

Tel: +358 9 340 1716
Fax: +358 10 296 2072

THAILAND

Radicon Transmission (Thailand) Ltd

700/43 Moo 6
Amata Nakorn Industrial Estate
Tumbol Klongtumru
Muang,
Chonburi
20000
Thailand

Tel: +66 3845 9044
Fax: +66 3821 3655

USA

Radicon Drive Systems, Inc.

2475 Alft Lane
Elgin
Chicago
Illinois
60124
USA

Tel: +1 847 593 9910
Fax: +1 847 593 9950

INDIA

Elecon. Engineering Company Ltd.

Anand Sojitra Road
Vallabh Vidyanagar
388120 Gujarat
India

Tel: +91 2692 236513

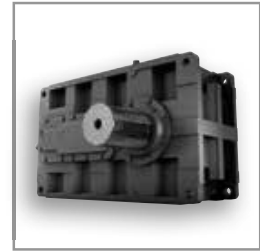
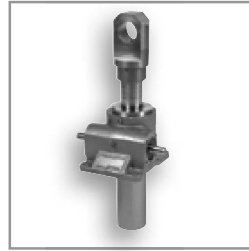

benzlers[®]
radicon[®]

Benzlers

Denmark +45 36 340300
Finland +358 9 3401716
Germany +49 800 3504000
Italy +39 02 824 3511
Sweden +46 42 186800
The Netherlands +31 77 3245900
www.benzlers.com

Radicon

Thailand +66 38459044
United Kingdom +44 1484 465800
USA +1 847 5939910
www.radicon.com