

DBH DISC BRAKES CALIPER air applied spring released

NIKA®

The **DBH** is an economic caliper brake, which offers a wide variety of thrusters and features.

Easy Pad Change: The pads can be changed in a couple of minutes.

Asbestos Free Pads : The standard pads fitted are asbestos free.

Brake Discs: The DBH104,105 designed for disc thickness 10MM and OD over 200mm

Torque Formula : Braking Torque (kgm) =Braking Force (kg) x Effective Disc Radius (Actual)(mm)



LEFT
TYPE

| Size | DBH 104 | DBH 105 |
|------------------------|----------------------|----------------------|
| Maximum under overload | 7 kg/cm ² | 7 kg/cm ² |
| Compression ratio | 1.83 | 1.83 |
| Disc thickness | 10 mm | 10 mm |
| Disc O. D. mm | 200↑ | 200↑ |
| Unit Weight | 8.5 kg | 9 kg |

Every **horizontal** caliper separate into the left and right type. Please indicate left or right side type when order.

● Torque versus Pressure

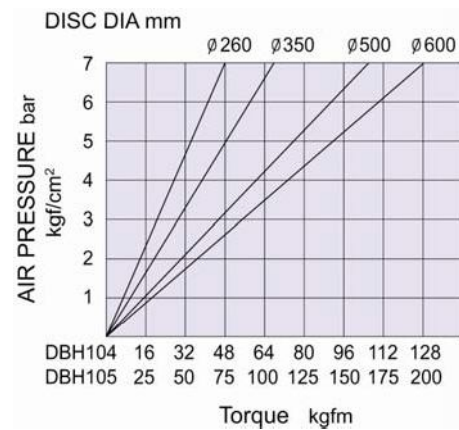

APPROXIMATE DIMENSION

| Size | X | Y | φZ |
|---------|-----|-------|-----|
| DBH 104 | 132 | 267.5 | 142 |
| DBH 105 | 152 | 285 | 177 |

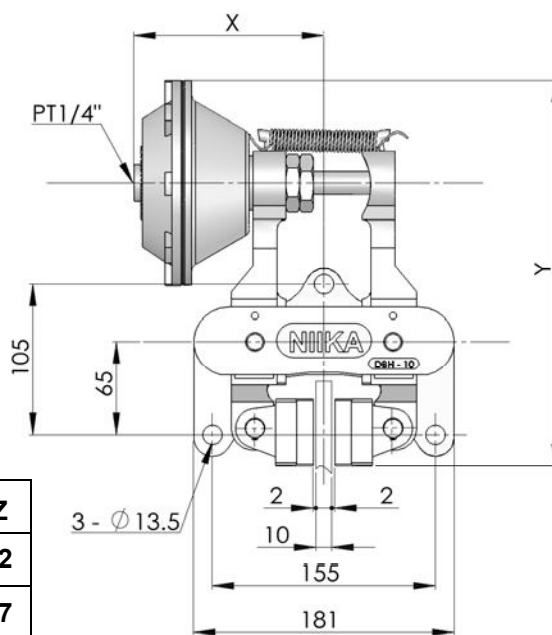

RIGHT TYPE

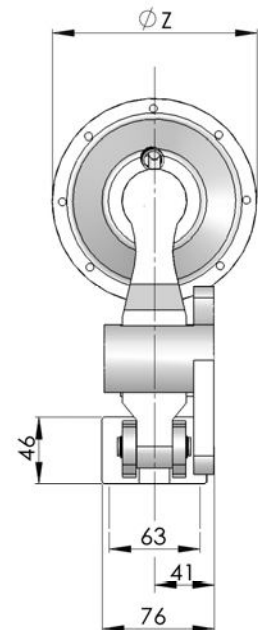

Warning : The initial torque on new units can be 30% to 50% less then the catalogue value until the friction facing and friction disc are lapped or worn in.

NIKA Limited reserves the right to modify or change the design without prior notice.